

# CONTINUOUS VACUUM PACKING MACHINE

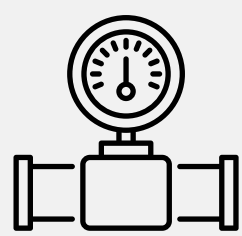

**Advanced  
Vacuum**



**Extended  
Shelf-Life**



**Hygienic & Safe  
Design**



**Secured  
Sealing**

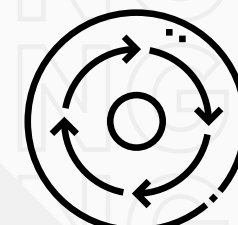

**Consistent  
Quality**



**IP65  
Standards**

The Continuous Vacuum Packing Machine offers unparalleled efficiency for high-volume packaging needs, ensuring products are securely sealed and preserved. With advanced PLC controls and a user-friendly interface, it allows for precise adjustments to vacuum levels and sealing times. Constructed from durable stainless steel, it guarantees longevity and reliability in various industrial settings. Enhance your production line with this state-of-the-art solution that minimizes waste and maximizes freshness.

The Continuous Vacuum Packing Machine specializes in delivering consistent, high-speed sealing for a wide range of products, enhancing shelf life while minimizing waste through its advanced vacuum technology.

The application is to preserve foods like sweets, dairy products, meat, seafood, dates, dry fruits & convenience foods etc.



### Easy to Operate

Designed with simplicity, our machine features an intuitive smart interface and straightforward controls, ensuring easy operation for all experience levels.

### Easy Maintenance

With a focus on convenience, our machine is engineered for easy maintenance, featuring accessible components and straightforward service procedures.

### Rapid Tech Support

Benefit from our 24\*7 rapid tech support, offering prompt assistance and solutions to minimize downtime and keep your machine running smoothly.

## DIMENSIONS

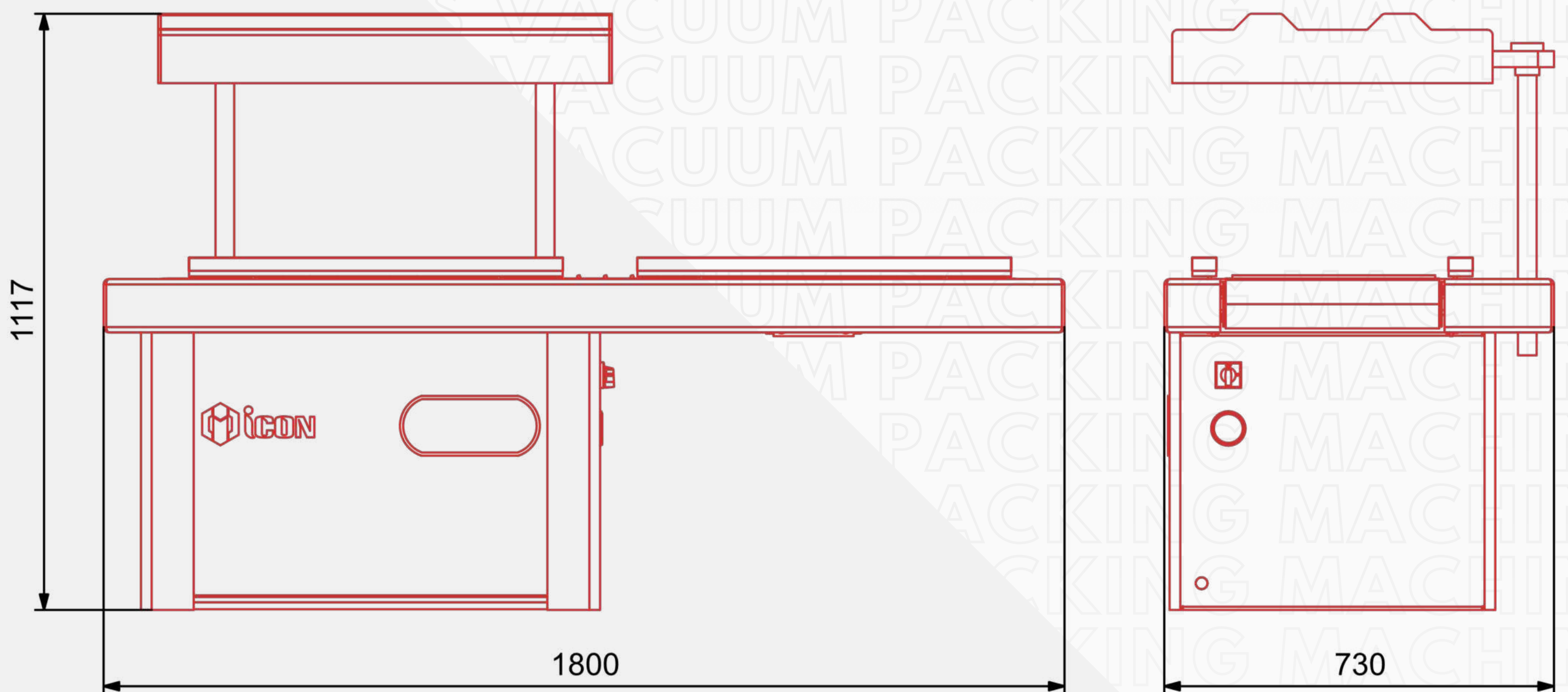

## TECHNICAL SPECIFICATIONS

Vacuum Chamber Size	740 x 550 x 100 mm.	Electrical Construction	Digital Electronic Control
Sealing Length	680 mm each	Body Construction	All Stainless Steel
Sealing Width	8 mm	Vacuum Chamber	Hygienic Stainless Steel
No. Of Sealing Bar	Two	Production	3 To 5 Cycle/Min (Depend On Product)
Distance (Between Two Sealing Bar)	435 mm	Machine Length	~1800 mm
Power Supply	890 w (220 v AC / 440 v AC)	Machine Width	~730 mm
Vacuum Pump	40 m3/h - Becker	Machine Height	~1120 mm

\*The above mentioned values are indicative and can be modified at any time at the discretion of the company.